

SET-UP SHEET

XRAY T4'14

RACE	2015 7th Annual TZGP		
TRACK	Time Zone Raceway		
NAME	awd		
CITY / COUNTRY	Wylie, TX	USA	
CONTACT	andrewdoherty@yahoo.com		

DATE	21/07/2015	TEMPERATURE / °F or °C	AIR	TRACK
------	------------	------------------------	-----	-------

QUALIFYING POSITION	BEST LAPTIME /sec	FINAL POSITION	RACE LENGTH /minutes
6	16.8	9	5

TRACK CONDITION	<input type="checkbox"/> CARPET	<input checked="" type="checkbox"/> ASPHALT	
<input type="checkbox"/> TECHNICAL	<input checked="" type="checkbox"/> MIXED	<input type="checkbox"/> FAST	
TRACTION	<input type="checkbox"/> LOW	<input checked="" type="checkbox"/> MEDIUM	<input type="checkbox"/> HIGH

FRONT	REAR
TRANSMISSION	

SOLID AXLE	<input checked="" type="checkbox"/> YES	BALL DIFFERENTIAL	<input type="checkbox"/> YES
SOLID ONE WAY DIFF.	<input type="checkbox"/> YES		
ONE WAY DIFFERENTIAL	<input type="checkbox"/> YES		

GEAR DIFFERENTIAL	<input type="checkbox"/> YES	GEAR DIFFERENTIAL	<input checked="" type="checkbox"/> YES
OIL		OIL	AE 6K /Cst

PINION / T	22	SPUR GEAR / T	84
FINAL DRIVE RATIO	3.8181818181818	ROLLOUT	0

FRONT	REAR
-------	------

2.5	XRAY SPRINGS	2.5
-----	--------------	-----

PS 500	OIL / CST	PS 500
57	LENGTH /mm	57

0	PRELOAD /mm	0
	REBOUND %	

<input type="checkbox"/> YES <input checked="" type="checkbox"/> NO	FOAM INSERTS	<input type="checkbox"/> YES <input checked="" type="checkbox"/> NO
<input type="checkbox"/> YES <input checked="" type="checkbox"/> NO	O-RING ON SHAFT	<input type="checkbox"/> YES <input checked="" type="checkbox"/> NO

<input type="checkbox"/> 3 HOLES	PISTONS	<input type="checkbox"/> 3 HOLES
<input checked="" type="checkbox"/> 4 HOLES	1.0mm	<input checked="" type="checkbox"/> 4 HOLES
	1.1mm	
	1.2mm	
	OTHERS	

1.3	THICKNESS/mm	ANTI-ROLL BAR	THICKNESS/mm	1.3
-----	--------------	---------------	--------------	-----

Sweep 36	TIRES	Sweep 36
Premount	INSERTS	Premount
FXII	ADDITIVE	FXII
5 on-5 off	ADDITIVE TIMING	5 on-5 off

FRONT LEFT	FRONT RIGHT	REAR LEFT	REAR RIGHT
TREATED AREA			

WHEELS	
S <input type="checkbox"/> M <input type="checkbox"/> H <input type="checkbox"/>	HARDNESS

MOTOR	HW V10 5.5	TIMING	30
ROTOR	Std	ARMATURE	Std

ESC	HW Xerun 3.1 2s	BATTERIES	Speedzone 6000
-----	-----------------	-----------	----------------

BODY	LTC-R LW	WING	PFH-STD DF
------	----------	------	------------

- APPLIED S-SOFT M-MEDIUM H-HARD

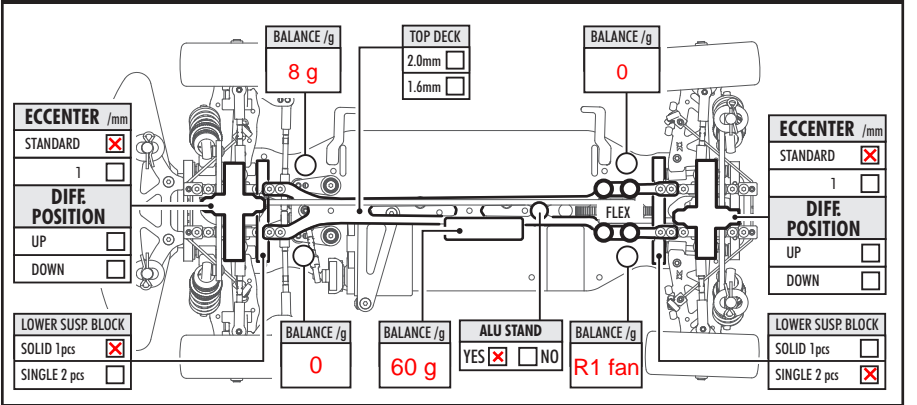
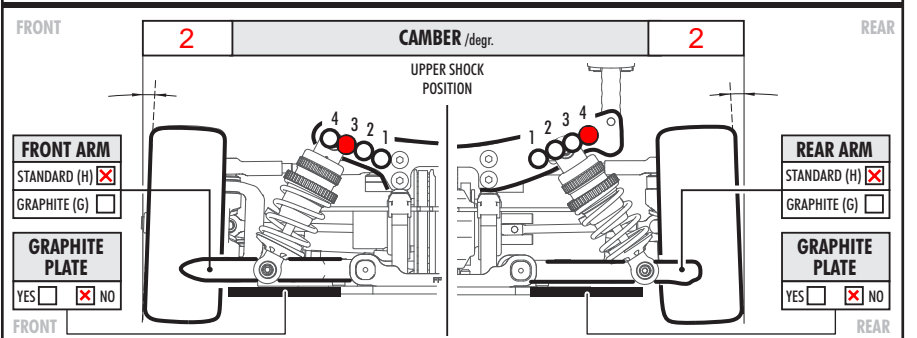
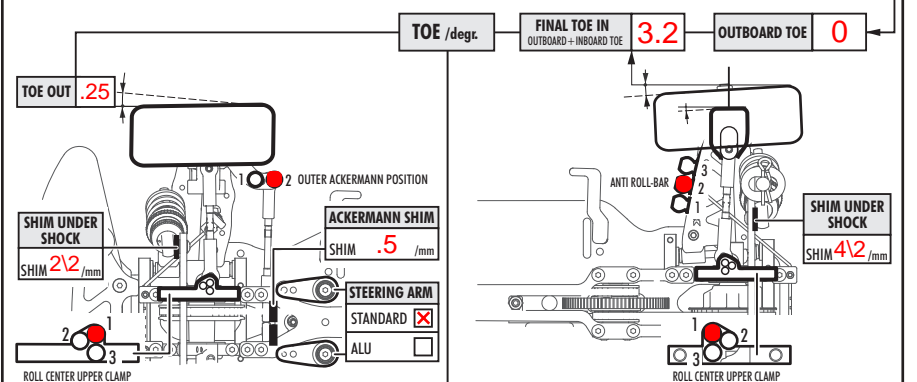
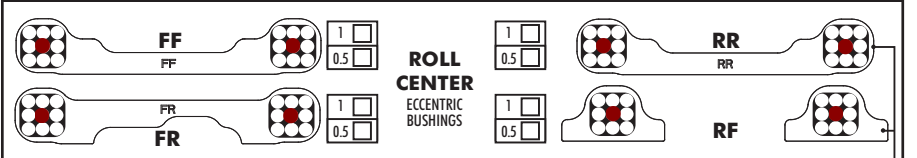
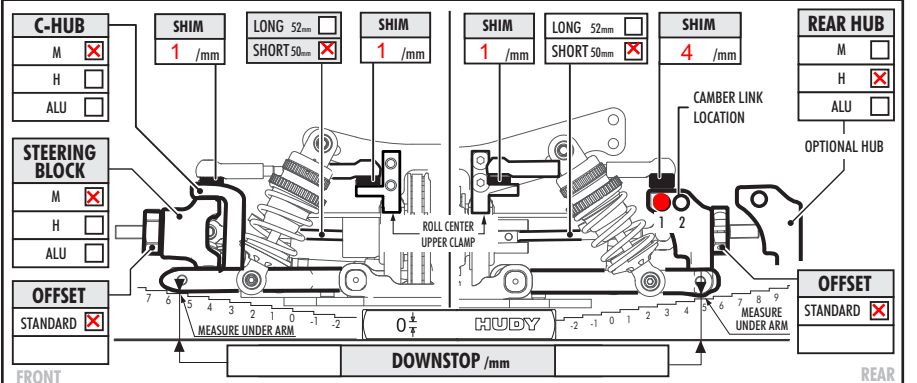
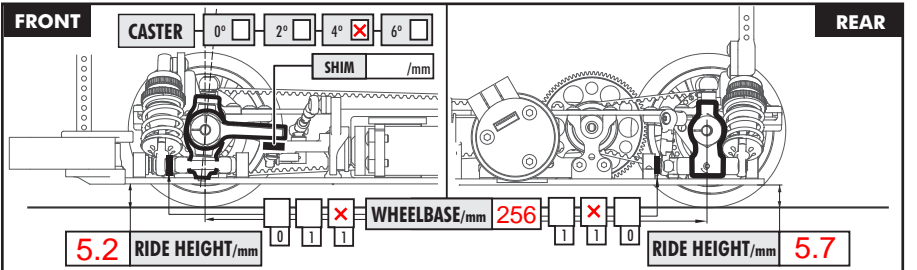

COMMENTS
 AVID 2.0 2015 carbon chassis
 AVID 1.5 soft top deck
 AVID F and R shock towers X2
 AVID Ti ball studs
 RSD Al spool cups
 RSD 80 mm ECS
 RSD narrow steering post
 RSD 2015 hand-boost bumper